

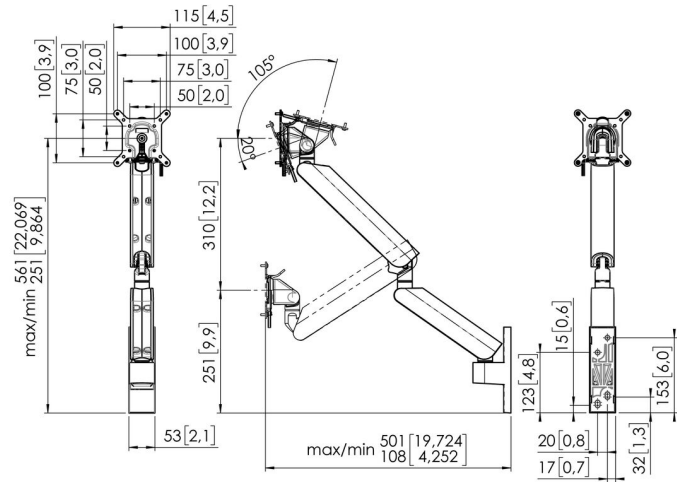

MOMO 4136 Monitor Arm Motion Plus for wall mounting (black)

Article number (SKU): 7141360
Colour: Black



Tender specifications

BRAND AND PRODUCT; Vogel's MOMO MOTION PLUS 4136; Monitor Mount; dynamic mount; colour: black/white; suitable for one monitor MARKET SEGMENTATION: Monitor Mounts ideal for use in a school, meeting room, lobby or boardroom; offices; market segment education; corporate; retail; hospitalitySUITABLE FOR: Suitable for monitors up to 43 inch; Max. weight of monitor 10 kg/22lbs; MATERIALS: dynamic arms aluminium; asa cover caps according to RoHs guidelines; FEATURES: TÜV-3 tested; endurance test of at least 10,000 cycles; FIRA; IGR; warranty 10 years; easy installation; mounting on wall; universal interface suitable for any brand of monitors up to 43 inch; weighing up to 10 kg / 22 lbs; 3 pivot points; 310 mm height adjustment; VESA size; 50x50/75x75/100x100; sivel 180; rotate 90/90; tilt -20/+105; rotation stop yes; environment-friendly packaging entirely without EPP I EPS; special MOMO accessories and components available for MOMO Monitor Mounts;TECHNICAL SPECIFICATIONS: Min. VESA 50x50mm Max. VESA 100x100; Height adjustment Mechanical spring; Rotation stop yes; Mounting possibilities on the wall; Adjustable height 310 mm; Max weight load 10kg/22,05 lbs; TUV-3 certified; MOMO Motion+; LOGISTICS INFORMATION: box dimensions (mm) 554 x 267 x 85 (LxWxH); gross weight 3,65 kg / 8,04 lbs (warehouse) 9;PRODUCT PROPOSITION: Vogel's MOMO The Monitor Mount that works everywhere; Vogel's Products BV.



Article number (SKU): 7141360
Colour: Black

Key Benefits

- Height Adjustable
- Suitable for one, two or a whole series of monitors
- Easy to assemble without tools
- Flexible modular system
- TÜV certified / 10-year guarantee

The ergonomic monitor arm for every workplace
The MOMO 4136 is a dynamic monitor arm specially designed for wall-mounted monitors. The monitor arm can bear screens up to 43 inches weighing up to 10 kg.

VOGEL'S HOLDING BV (©)

All rights reserved.
Subject to printing errors, technical and price amendments.

Date: 2024-03-26