

## S052.7150B Motorized Display Floor-Wall Lift

### Key Benefits

- 3 step installation in 20 minutes
- Ample storage space for AV equipment

This floor lift offers thanks to its double columns extra stability and robustness for working with a touch display. The display can easily be adjusted in height with the remote control, it adjusts it silently & electrically in height. At the back side of the mounting utility, space is reserved for placing a mini PC or thin client. This product is easily combined with the accessories of the floor lifts (for example five surface solution, soundbar bracket or a compact lockable cover).



Smart  
metals  
MOUNTING SOLUTIONS

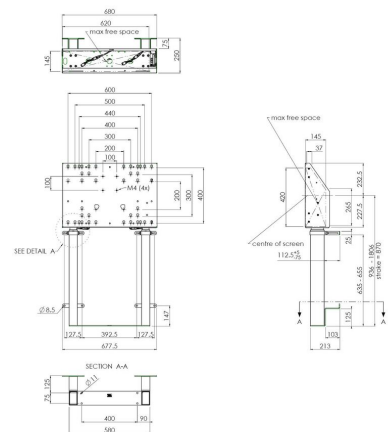



## S052.7150B Motorized Display Floor-Wall Lift



# Specifications

Motorized	Yes
Max. weight load (kg)	120
Max. weight load (Lbs)	264.55
Anti Collision safety mechanism	Yes
Article number (SKU)	S052.7150B
EAN single box	8718868870599
Colour	Black
Certifications	CE TÜV
TÜV certified	Yes
Guarantee	5 years

VOGEL'S HOLDING BV (©)

All rights reserved.  
Subject to printing errors,  
technical and price  
amendments.

Date: 2024-09-26



**Vogel's.** For Sure.