

## PUC 2515 Pole 150 cm (black)

The PUC 2515 is a 150 cm pole and is a part of the modular Connect-it system with which you can create a ceiling solution for medium- to large-sized displays.

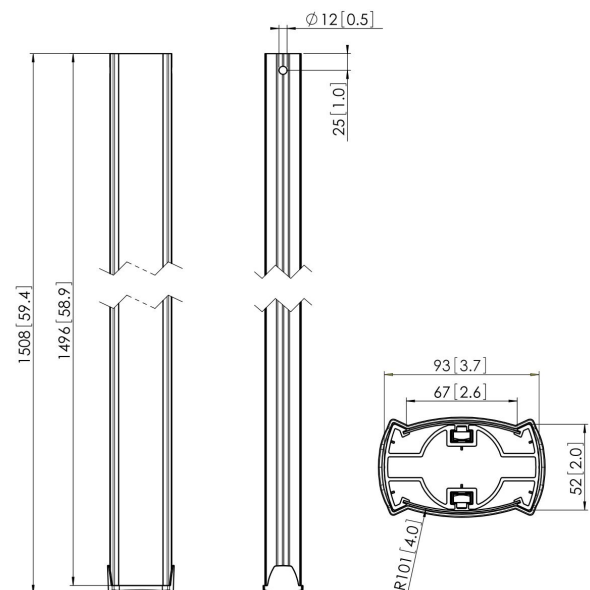



## PUC 2515 Pole 150 cm (black)

# Specifications

Article number (SKU)	7225150
Colour	Black
EAN single box	8712285329364
Length	1500
TÜV certified	Yes
Guarantee	5 years
Max. weight load (kg/Lbs)	80 / 176.37
Back-to-back displays	True
Conned It exceptions	2x if inches gte 65

VOGEL'S HOLDING BV (©)

All rights reserved.  
Subject to printing errors,  
technical and price  
amendments.

Date: 2023-01-25

