

## PFI 3010 Display interface

Article number (SKU) 7230100  
 Colour Black

### Key Benefits

- Post-installation levelling
- Tilt function in steps

The PFI 3010 display interface is a part of the modular Connect-it system with which you can create your own ceiling solution for small- to medium-sized displays.

The PFI 3010 is suitable for small- to medium-sized displays (VESA 75x75 or 100x100 mm) up to 30 kg. This interface is equipped with a levelling and tilting function (incremental 0-10-20°).

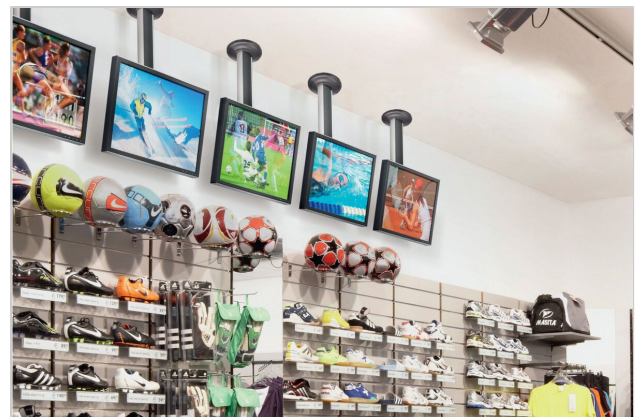
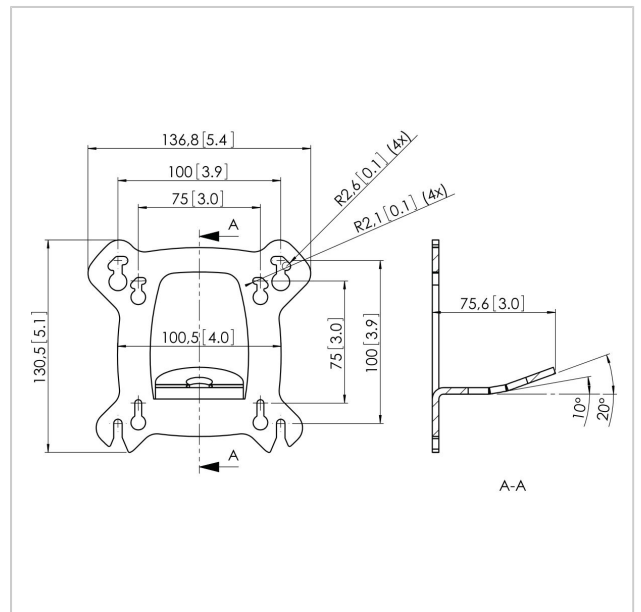



## PFI 3010 Display interface

[www.vogels.com](http://www.vogels.com)

VOGEL'S HOLDING BV 2019 (c) All rights reserved.  
Subject to printing errors, technical and price amendments.  
Date: 2019-05-10

## Specifications

Product type number	PFI 3010
Article number (SKU)	7230100
Colour	Black
EAN single box	8712285317262
TÜV certified	Yes
Tilt	Tilt up to 20°
Guarantee	5 years
Max. weight load (kg)	30
Max. bolt size	M6
Max. height of interface (mm)	130
Max. width of interface (mm)	137

