

RISE A216 Whiteboard Set 65" RISE 2xxx

Article number (SKU): 7302160
Colour: White

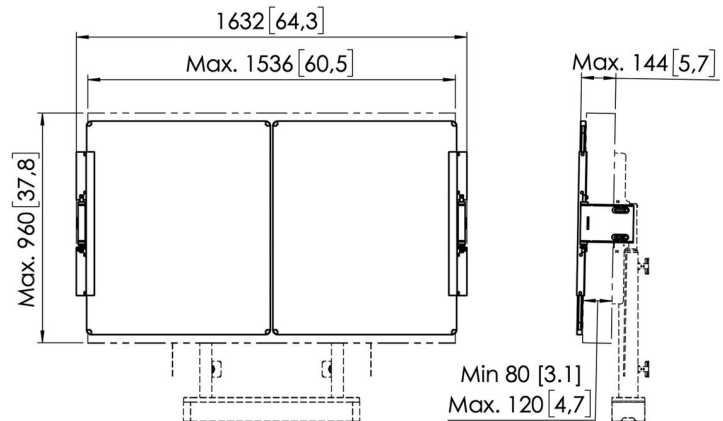

Tender specifications

BRAND AND PRODUCT: Vogel's RISE A216; Whiteboard Set 65" for RISE motorized display lift floor-wall solution; colour: white; MARKET SEGMENTATION: motorized display lift ideal for use in a school, meeting room, lobby or boardroom; market segment education; market segment corporate; SUITABLE FOR: special accessory only for RISE motorized display lift floor-wall solution; fits any brand of 65 inch screen; MATERIALS: set of 2 including extension bar; enamel coated on 2 sides; stainless steel rims; hinges white powder coated according to RoHs guidelines; aluminium interface bar; FEATURES: TÜV-5 tested; TAA compliant; warranty 5 years; easy assembly; set of 2 pieces and 1 interface bar; mount a whiteboard left and right of interactive flat panel display 65 inch; adjustable hinges allow to vary the depth, height and width for perfect alignment on any screen; Vogel's in-house development hinges; the whiteboards do not spontaneously open, even after frequent use; whiteboard set moves with lift speed RISE display lift (80mm/s or 50mm/s) with screen up to 120 kg; suitable for alcohol-based markers; environment-friendly packaging entirely without EPP | EPS; TECHNICAL SPECIFICATIONS: Suited for 65" screen; height adjustable till 75mm / 3.0 inch; tilt -4/+4 degrees; Min. - Max. depth adjustable, 80 - 120 mm / 3.1 - 4.7 inch; Min.- Max. distance floor to centre display 806 - 1786 mm / 31.7 - 70.3 inch; distance mid VESA up to top edge 446mm / 17.6 inch; total width when opened including 65 inch screen: 3166mm / 124.6 inch; total width when closed 1632mm / 64.3 inch; product height x width 1 whiteboard 892 x 767mm / 35.1 x 30.2 inch; net weight 21 kg / 46.3 lbs; interface bar length x width x height 658 x 31 x 137mm / 25.9 x 1.2 x 5.4 inch; LOGISTICS INFORMATION: box dimensions 1 (mm) 943 x 793 x 90 / (inch) 37.1 x 31.4 x 3.5; box dimensions 2 (mm) 1175 x 395 x 62 / (inch) 46.3 x 15.5 x 2.4; total gross weight 22 kg / 48.5 lbs; PRODUCT PROPOSITION: Motorized display lift for intuitive and safe use of a screen at the correct height; Vogel's Products BV.



Article number (SKU): 7302160
Colour: White

Key Benefits

- Complete your RISE Display lift with handy accessories
- For mounting on the RISE floor-wall solutions
- Quick and easy installation
- TÜV-5 certified

Whiteboard Set for 65"

This RISE A216 Whiteboard Set 65" is custom made for the Vogel's RISE motorized display lift floor-wall solution. With this accessory, you can mount a whiteboard to the left and right of a 65-inch display. The enamel steel boards feature hinges developed by Vogel's. As a result, the whiteboards do not spontaneously open, even after frequent use.

Easy to install

The adjustable hinges on this accessory set allow you to vary the depth, height and width so that the whiteboards always fit the display, whatever display you are using.

Sustainability is a key component of the RISE Series display lifts. Vogel's offers an endurance tested design of the display lift of over 30,000 cycles. No EPP | EPS is used in the packaging. There is also a reduction of 85% single used plastic in the packaging. This keeps waste streams to a minimum.

VOGEL'S HOLDING BV (©)

All rights reserved.

Subject to printing errors, technical and price amendments.

Date: 2025-01-27