



## RISE 5305 Motorized Display Lift Cart 50 mm/s (black, US)

### Key Benefits

- Height adjustment range of no less than 980 mm
- Movement speed of 50 mm/s for the heaviest screens with QuickRise®
- TÜV, CE, UL and GS certified
- Specially designed foot for extra safety
- Anti-collision on the display lift prevents damage

### Screen moved smoothly and safely to the correct height

A RISE 5305 motorized display and TV lift trolley is suitable for displays of up to 98" and 120 kg max. The lift raises the screen smoothly, quickly and safely at a speed of 50 mm/s with QuickRise™. With a 980 mm travel range the lift is suitable for both very low and high positions. The top-down assembly ensures quick installation. We offer a 5 year guarantee. Safety first Vogel's display lift systems comply with the highest international safety standards of TÜV, CE, UL and GS. Although they are programmed for 86-inch screens, these motorized lift systems can be used for most 98" monitors. A small software adjustment (height adjustment) may occasionally be required (see user manual).

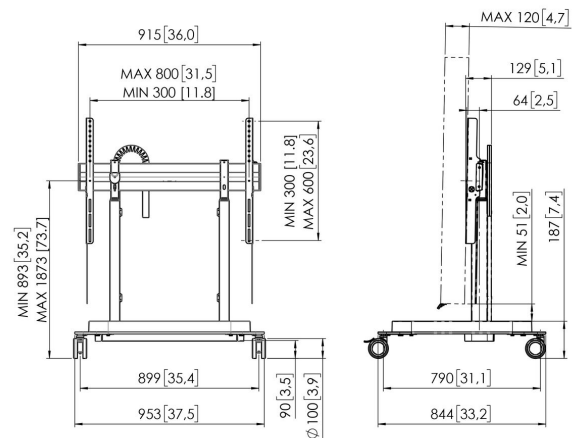



## RISE 5305 Motorized Display Lift Cart 50 mm/s (black, US)



### Specifications

Motorized	Yes
Min. screen size (inch)	55
Min. screen size (inch)	55
Max. screen size (inch)	98
Max. screen size (inch)	98
Min. horizontal hole pattern (mm)	200
Max. horizontal hole pattern (mm)	800
Min. vertical hole pattern (mm)	200
Max. vertical hole pattern (mm)	600
Min. distance to floor - center display (mm)	893
Max. distance to floor - center display (mm)	1873
Max. weight load (kg)	120
Max. weight load (Lbs)	264.55
Height adjustment (mm)	980
Height	1205
Width	955
Depth	846
Article number (SKU)	7353052
EAN single box	8712285358067
Colour	Black
Certifications	CE GS UL
TÜV certified	Yes
Guarantee	5 years

VOGEL'S HOLDING BV (©)

All rights reserved.  
Subject to printing errors,  
technical and price  
amendments.

Date: 2024-08-22



**Vogel's.** For Sure.