



MOMO 4126B Monitorarm Motion Plus

Key Benefits

- Height Adjustable
- Suitable for one, two or a whole series of monitors
- Easy to assemble without tools
- Flexible modular system
- TÜV certified / 10-year guarantee

The ergonomic monitor arm for every workplace The MOMO 4126 is a dynamic monitor arm specially designed for wall-mounted monitors. The monitor arm can bear screens up to 43 inches weighing up to 10 kg.

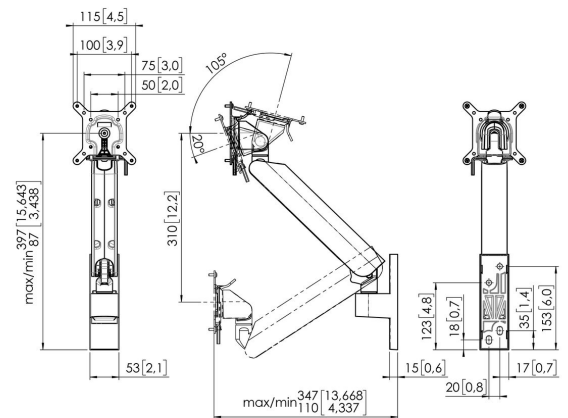



MOMO 4126B Monitorarm Motion Plus



Specifications

| | |
|---------------------------------|-----------------------------------------|
| Min. screen size (inch) | 10 |
| Max. screen size (inch) | 43 |
| Universal or fixed hole pattern | Fixed |
| Max. height of interface (mm) | 115 |
| Max. width of interface (mm) | 115 |
| Max. weight load (kg) | 10 |
| Max. weight load (Lbs) | 22.05 |
| Max. load curved display (kg) | 10 |
| Max. load curved display (Lbs) | 22.05 |
| Turn | Up to 180° |
| Number of pivot points | 2 |
| Rotate | Up to 180° |
| Tilt | Tilt -20°/+105° |
| Height adjustment | Mechanical spring, OneFingerMovement |
| Adjustable depth | Yes |
| Adjustable height | Yes |
| Mounting Possibilities | On the wall |
| Article number (SKU) | 7141260 |
| EAN single box | 8712285353468 |
| Colour | Black |
| Certifications | IGR TÜV |
| Guarantee | 10 years |

VOGEL'S HOLDING BV (©)

All rights reserved.
Subject to printing errors,
technical and price
amendments.

Date: 2025-06-17



Vogel's. For Sure.